

3000W MULTI PIR LIGHT CONTROLLER

Cat No. MLB3000 - Black
Cat No. MLW3000 - White



Installation & Operating
Instructions



INSTALLATION & OPERATING
INSTRUCTIONS

SECTION ONE

GENERAL INFORMATION

The unit utilises passive infrared technology to detect heat radiation of moving human bodies.

Upon detection, the lamp will illuminate for a user-determined time period.

An integral daylight sensor ensures night-only operation.

PARTS INCLUDED

- PIR Sensor unit.
- Instruction manual. Please keep safe for future reference.
- Accessory Pack.

TOOLS & PARTS NEEDED

- Electric/hand-held drill & bits.
- Terminal or Electricians screwdriver
- Large slotted/philips screwdriver
- Wire cutters

This product is suitable for wall or ceiling mount.

Lighting loads connected must not exceed maximum 3000W filament/incandescent, 500W fluorescent/low energy.

SECTION TWO

SELECTING THE LOCATION

The motion detector has a number of detection zones, at various vertical and horizontal angles as shown (see diagram A).

A moving human body needs to cross/enter one of these zones to activate the sensor. The best all-round coverage is achieved with the unit mounted at the optimum height of 2.5m.

Careful positioning of the sensor will be required to ensure optimum performance. See diagram A detailing detection range and direction.

The sensor is more sensitive to movement ACROSS its field of vision than to movement directly TOWARDS (see diagram B). Therefore position the unit so that the sensor looks ACROSS the likely approach path.

Avoid positioning the sensor where there are any sources of heat in the detection area (extractor fans, tumble dryer exhausts etc.).

Reflective surfaces (ie pools of water or white-painted walls) and overhanging branches may cause false activation under extreme conditions.

During extreme weather conditions the motion sensor may exhibit unusual behaviour. This does not indicate a fault with the sensor. Once normal weather conditions return, the sensor will resume normal operation.

SECTION THREE

INSTALLATION

After choosing a suitable location (see previous section) install the unit as follows:

*** IMPORTANT ***

Switch off the electricity at the fuse box by removing the relevant fuse or switching off the circuit breaker before proceeding with the installation.

Remove the wiring box cover by unscrewing the retaining screw (fig F) and with a screwdriver gently push down and ease out.

The unit is suitable for connection to a 230 V ac 50Hz electricity supply. It is suggested that 3-core round flexible cable of 1mm² gauge is used. A isolating switch should be installed to switch the power to the unit ON & OFF. This allows the sensor to be easily switched off when not required or for maintenance purposes.

Mark the position of the fitting holes.

Drill the holes. Insert the rawl plugs into the holes.

PIERCE & PASS THE CABLE(S) THROUGH THE GROMMET(S) BEFORE PROCEEDING.

Fix the mounting plate to the wall. Take care not to overtighten the screws to prevent damage to the mounting plate. If using a power screwdriver, use the lowest torque setting.

CONNECTION

This unit is supplied with a hanging attachment (tether) to aid installation.

If it is not required, simply remove from the unit and discard.

Place the round end of the tether into the keyhole shape location hole on the wall bracket. Ensure the tether is securely fixed into the slot before releasing the weight of the unit.

The unit can now be suspended below the wall bracket. (Fig D)

Connect the mains supply cable to the terminal block as follows (see connection diagram):

NEUTRAL (Blue)	N
EARTH (Green/Yellow)	
LIVE (Brown)	L

Connect the cable from the lighting load to the terminal block on the unit as follows: (see connection diagram)

NEUTRAL (Blue)	N
EARTH (Green/Yellow)	
LIVE (White)	L1

Ensure the connections are secure.

Place terminal block onto its securing pillar on the wall bracket (Fig E)

Remove and discard the tether.

Fit control to wall bracket and secure by fixing screw (Fig F)

TOP VIEW

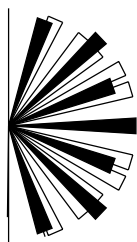

200°

A

SIDE VIEW



12m

C

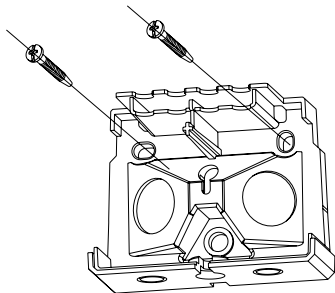

B

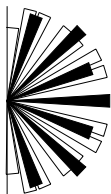

Less
sensitive

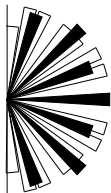

More
sensitive

D

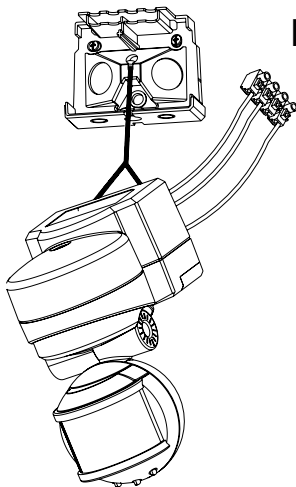

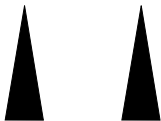

Place this edge against wall
and use diagram to
estimate incoming cable
length

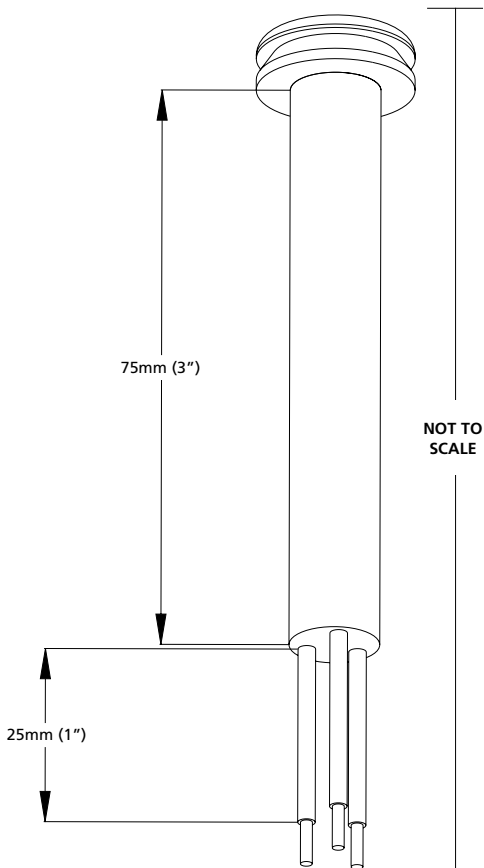

INCOMING WIRE TEMPLATE

Use this diagram to estimate incoming cable length

CONNECTION DIAGRAM

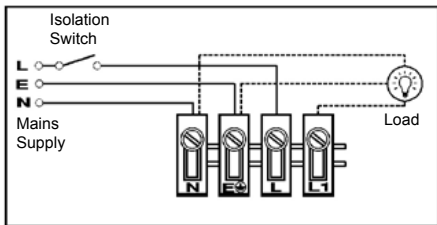

SECTION FOUR OPERATION AND TESTING

WALK TEST PROCEDURE

The sensor will rotate from left to right, and tilt forward or backward. Adjust the sensor to point in the required direction. (note diagram B)

The unit can be set up in daylight or at night. The adjustment knobs are factory set. Lux is set to the 'moon' setting and Time is set to a minimum (fully anti-clockwise) see diagram G.

Turn the power to the unit on. The lamp will illuminate for approximately 30 seconds. This indicates the unit is wired correctly.

After approximately 30 seconds the light will turn off.

The unit is now in Test Mode.

TEST MODE - THREE LEDS VISIBLE

The lamp will now illuminate for approximately 2 seconds every time movement is detected. Walk across the detection area approximately 5 metres from the unit. Each time you are detected the lamp will illuminate. Now stand still until the lamp extinguishes (this should take approx. 2 seconds)

Start moving again, when you are detected again the lamp will illuminate.

Repeat the above, walking at various angles and distances to the unit. This will help you to establish the detection pattern.

If the detection area is too small for your requirements, try angling the sensor head up. Angling the head downwards will reduce the detection area should a smaller range be required.

SETTING UP FOR AUTOMATIC OPERATION - 3 SCROLLING LEDS VISIBLE

When walk tests are complete, the unit will switch into Automatic Mode.

Simply cease movement within the detection area for approximately 60 seconds. The unit will then switch to Automatic Mode, this is indicated by the illumination of three scrolling LEDs in the top transparent area of the sensor head. These LED's will scroll from left to right during daylight and darkness.

The TIME setting controls how long the unit remains illuminated following activation and after all motion ceases.

(See diagram G. the time adjustment knob is indicated by the "Clock" symbol).

The minimum time (fully anti-clockwise) is approx. 5 seconds, whilst the maximum time (fully clockwise) is approx. 5 minutes. Set the control to the desired setting between these limits.

The DUSK control determines the level of darkness required for the unit to start operating. The setting is best achieved by the procedure below:

(See diagram G. the Dusk adjustment knob is indicated by the "Moon" and "Sun symbols).

Set the DUSK control knob fully anti clockwise. Wait until darkness falls.

When the ambient light level reaches the level of darkness at which you wish the lamp to become operative (i.e.: at dusk) SLOWLY rotate the control in a clockwise direction until a point is reached where the lamp illuminates. Leave the control set at this point.

At this position the unit should become operative at approximately the same level of darkness each evening. Observe the operation of the unit. If the unit is starting to operate too early (i.e.: when it is quite light) adjust the control slightly anti-clockwise. If the unit starts to operate too late (i.e.: when it is very dark). Adjust the control slightly clockwise. Continue to adjust until the unit operates as desired.

The LED's will scroll from left to right, day and night; indicating the unit is in Automatic Mode. The LED's will extinguish when the PIR activates the light for as long as the lamp is illuminated.

MASKING THE SENSOR LENS

To restrict the sensor coverage, preventing detection in unwanted areas, mask the sensor lens using the masks provided in the accessory pack (see diagram H). For your information, the top section of the lens covers long range detection, the bottom covers short range. Similarly the left and right lens sections cover the left and right detection areas respectively.

MANUAL OVERRIDE MODE - SINGLE LED ILLUMINATED

The light can be switched on for longer time periods by use of the Manual Override Mode. This can be activated at night by using the internal wall switch or circuit breaker.

Switch the internal wall switch/circuit breaker twice (on/off, on/off) within 2 seconds. The unit will now illuminate continuously until dawn or until it is switched back into Auto Mode.

Manual Override Mode is indicated by the permanent illumination of a single red LED in the top of the sensor head.

To switch the unit back into Auto Mode, flick the internal wall switch/circuit breaker off/on once within 1 second. The unit will return to Auto Mode. This is indicated by the return of the left to right scrolling LED's as described in Automatic Operation above.

HOLIDAY MODE - SINGLE LED FLASHING

The benefit of Holiday Mode is that the user can program the unit automatically illuminate for a certain time, (1 - 8 hours) each night. At dusk the unit will illuminate for this set period after which it will extinguish. The unit will continue to operate normally when it senses movement until dawn. At dusk the following night the process will be repeated, the unit will remain on for this set period (0 - 8 hours) then operate as a PIR unit until dawn.

HOLIDAY MODE

Switch the internal wall switch/circuit breaker 3 times (off/on off/on off/on) within 2 seconds. A single flashing red LED at the top of the sensor head indicates Holiday Mode.

The unit will now illuminate for a user defined time between 1 and 8 hours. The time can be set by rotating the centre adjustment knob as required. (See diagram G, the adjustment knob is identified by the letter T inside a circle.)

Do not adjust this setting if you do not wish to use the Holiday Mode facility. This time adjustment is factory set to 1 hour.

Please note: Fully anticlockwise is 1 hour, fully clockwise is 8 hours.

After the defined period has elapsed, the unit will return to Automatic Mode and operate as previously set up and the three scrolling LED's will illuminate from left to right.

Holiday Mode will NOT reset to Automatic Mode at dawn, it will repeat each night until reset by the user.

To cancel Holiday Mode, switch the internal wall switch/circuit breaker once (off/on) within one second. The unit will turn to Automatic Mode indicated by the scrolling LEDs.

SECTION FIVE

TECHNICAL SPECIFICATIONS

Detection Range	Up to 12 metres
Detection Angle	200°
Power Supply	230 V AC ~ 50Hz
Maximum Switchable Load	3000W Filament/Incandescent or 500W Fluorescent/Low Energy
Time On Adjustment	5 seconds - 18 minutes
Dusk Level Adjustment	Day & night or night only operation
Environmental Protection	IP55 (suitable for outdoor use)
EC Directives	Conforms to 73/23/EEC. 89/336/EEC

**If you experience problems refer to Troubleshooting Guide.
If problems still exist, do not immediately return the unit to store.**

Telephone the Timeguard Customer Helpline

020 8450 0515

Qualified Customer Support Co-ordinators will be on-line to assist in resolving your query.

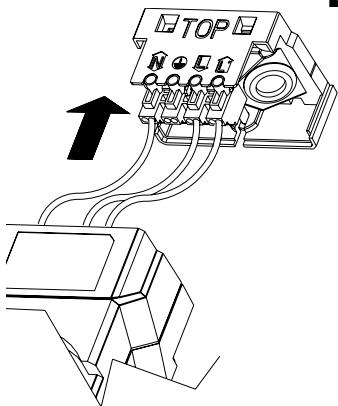
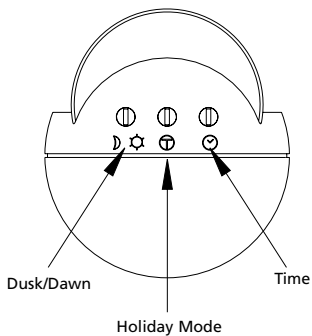
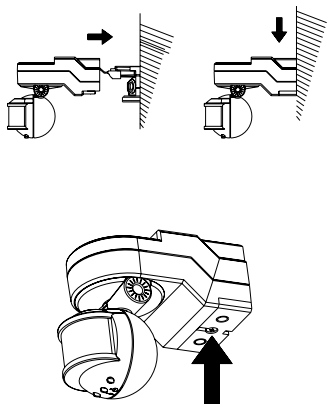
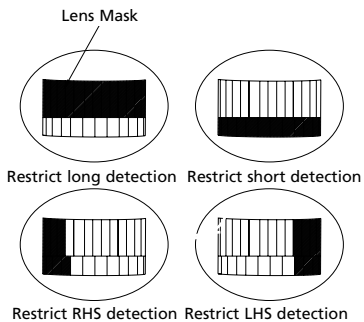
E**G****F****H**

SECTION SIX

TROUBLESHOOTING GUIDE

PROBLEM

SOLUTION

❑ Lamp stays ON all the time at night.

The unit may be suffering from false activation. Cover the sensor lens completely with a thick cloth. This will prevent the sensor from "seeing" anything. If the unit now switches off after the set time duration and does not re-activate, this indicates that the problem was caused by false activation. The problem may be solved by slightly adjusting the direction/angle of the sensor head (see previous section).

Check LED status:-

If a single LED is constantly visible, the unit is in Manual Override Mode and will illuminate until dawn or until reset to Automatic Mode.

To reset to Automatic Mode, switch the internal switch/circuit breaker off/on within one second.

Automatic Mode is indicated by scrolling LEDs from Left to right.

If a single flashing LED is visible, Holiday Mode has been selected. Switch the internal wall switch/circuit breaker off/on with one second and the unit will return to Automatic Mode. The light will illuminate only when motion is detected.

Automatic Mode is indicated by scrolling LEDs from Left to right.

❑ PIR keeps activating for no reason / at random.

You may not be allowing the unit time to complete its warm-up period. Stand well out of the detection range and wait (the warm-up period should never exceed 5 minutes).

Occasionally, winds may activate the sensor. Sometimes passages between buildings etc. can cause a "wind tunnel" effect.

Ensure the unit is not positioned so as to allow detection of cars/people using public thoroughfares adjacent to your property.

❑ PIR sensor will not operate at all.

Check that the power is switched ON at the circuit breaker/internal wall switch.

Turn OFF the power to the unit and check the wiring connections as per the diagram (see previous section 3). Ensure no connections are loose.

Check the lamp. If the lamp has failed, replace. Ensure that the lamp is seated correctly in the lampholder.

❑ The PIR sensor will not operate at night.

The level of ambient light in the area may be too bright to allow operation at the current DUSK setting. During the hours of darkness, adjust the DUSK control slowly clockwise until the lamp illuminates. Refer to previous section for more details.

PROBLEM

Unit activates during the daytime

PIR coverage is poor/ sporadic

Detection range varies from day to day

SOLUTION

The level of ambient light in the area may be too dark for the current DUSK setting. During daylight, adjust the DUSK control slightly anti-clockwise. When the lamp load extinguishes, enter the detection area. If the PIR still activates, the setting is still too high. Repeat the above procedure until the PIR does not activate when you enter the detection area. Refer to previous section for more details.

Unit may be poorly located. See previous section - 'Selecting The Location' and re-locate the unit.

PIR sensors are influenced by climatic conditions. The colder the ambient temperature, the more effective the sensor will be. You may need to make seasonal adjustments to the sensor head position to ensure trouble-free operation all year round.

5 YEAR GUARANTEE

In the unlikely event of this product becoming faulty due to defective material or manufacture, within 5 years of the date of purchase, please return it to your supplier in the first year with proof of purchase and it will be replaced free of charge. For years 2 to 5 or any difficulty in the first year telephone our helpline on 020 8450 0515.



For assistance with the product please contact:-

HELPLINE

020-8450-0515

or email helpline@timeguard.com



For a product brochure please contact:

Timeguard Ltd.

Victory Park, 400 Edgware Road,
London NW2 6ND Tel: 020-8452-1112

or email csc@timeguard.com

A **theben** Group company